



I N V E N T A B L E S .

X-Carve Pro Maintenance and Service Procedures

760-00021

Outline

This document is intended for internal and external consumption and to be used as reference for field service issues and maintenance recommendations.

Please read the X-Carve Pro Safety Manual and familiarize yourself with safe operation of the machine.

The controller is not an approved user serviceable component. Do not attempt to modify or open the controller. Such actions can void your warranty.

Regular maintenance

Vacuuming and cleaning

Regularly clean and vacuum the machine removing dust and debris from the linear rails and ball screws. Take special care to remove dust from the X axis ball screw, X axis cavity, Z axis ball screw nut, Y axis linear rails.

Recommended Parts/tools:

- Vacuum
- Hose attachment

Maintenance interval

- Daily

Spindle

Check and replace your collet when clogged with dust or cracked to maintain optimal performance from your machine.

Maintenance interval

- Check daily

Controller dust filters

Check your controller's dust filters (1 on front, 1 on back) occasionally to ensure it is not clogged. If it is clogged, then it has to be replaced. This ensures that the controller is not overheating and maintains optimal performance.

Recommended Parts/tools:

- Dust filter assembly - SKU 30875-36

Maintenance interval

- Check weekly

Maintenance for linear rails and ball screws - grease

The linear rails and ball screws on your X-Carve Pro come pre-greased from the factory. Generally, customers should not need to regrease the linear guides or ball screws before 6 months of regular use. However, we recommend that the customer check the grease levels every few months. This can be done by touching the rail after sliding back and forth to see if the rail is slightly greasy. If not, then lubrication is low and should be replenished.

We recommend using the Inventables approved grease and grease gun SKU: [30897-01](#)

Note:

1. X and Z-axis has 4 guide blocks that require grease
2. Each Y-axis has 2 guide blocks that required grease

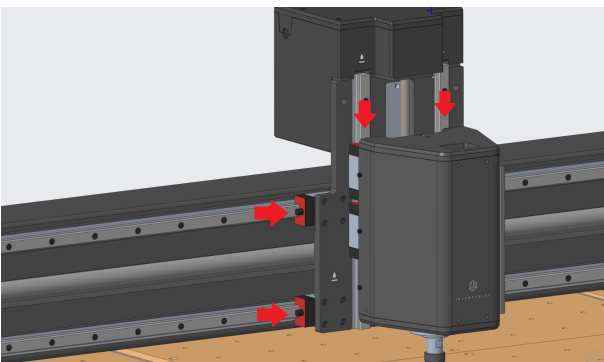
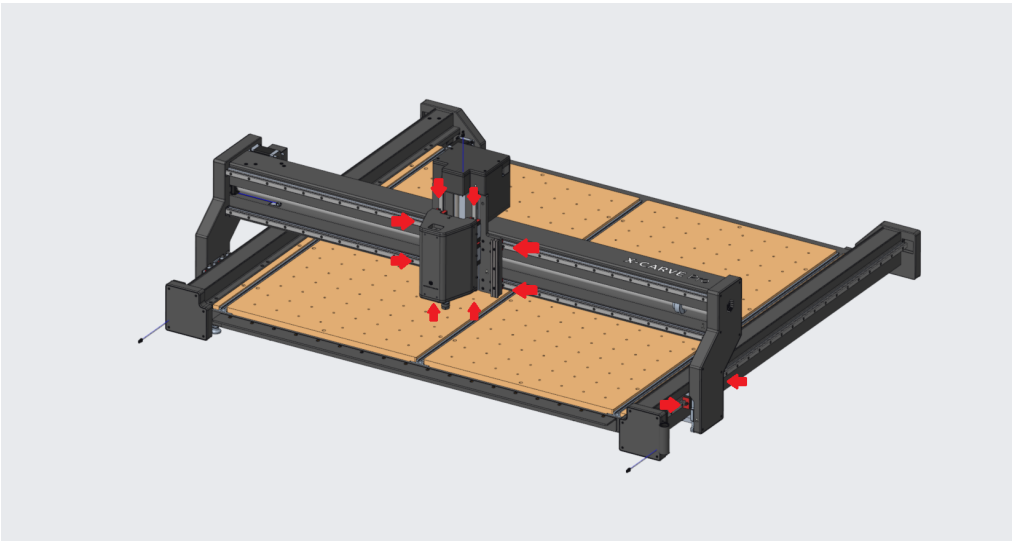

First connect your machine and open up an Easel project. Home the machine, then move the X axis 24" to the right and the Y axis 10" to the back for easy access to the grease points. Then open the grease gun packaging and assemble the gun as shown in the picture below. Pump the grease gun until you see grease come out of the nozzle. Push the nozzle firmly against the grease nipple in the guide block, squeeze the black tube, and pump the grease gun a few times until you see grease ooze out of the sides of the guide blocks.



For the ball screw, wear protective gloves and smear a 1" long line of grease directly on the ball screw on each side of the ball screw nut.

Note: You will need to lubricate the X, Y1, Y2 and Z ball screws

Once grease has been inserted to all the guide blocks and ball screws, open the "[Grease Maintenance](#)" Easel file to spread the grease within the internal components of the guide blocks.

- First go to the Grease Maintenance project, and home the machine by clicking the home button.
- Then click "Carve" to start the project. Jog the z-axis ~1" down, set the current position manually as your XY work zero, and start the carve. You will not use the Z-Probe for this project.
- The machine will move back and forth 5 times in all axes to spread the grease

Recommended Parts/tools:

- Grease gun and grease [SKU: 30897-01](#)

Maintenance interval:

- Check lubrication levels every 2 months of operation

Belt Tensioning

The belts used in the X-Carve Pro are synchronous belts whose tension is set at the factory; they don't require very high tension to operate properly. New rubber belts tend to stretch and loosen during operation in the first few weeks/months, after which they will tend to operate normally at lower tensions. Caution: high belt tensions can induce high forces on the motor shaft and ball screw shaft which can severely damage the machine, please reach out to Inventables Customer Service on instructions to set the appropriate belt tension.

User Serviceable parts

Fuses replacement

- The X-Carve Pro fuses are located in the power entry module of the controller, in a compartment between the power switch and the power plug.
- Turn off the machine and unplug the power cord before proceeding.
- Use a small flat head screwdriver to pull and open the cap. Use tweezers to remove the old fuses and install the new ones
- Push the cap back into the assembly

Recommended Parts/tools:

Fuses - 30875-02

Spindle replacement

- Ensure your machine is turned off and the power cord is unplugged from your controller.
- Using a 2.5mm allen wrench remove the 6 screws on the sides of the spindle cover.
- Lift up the spindle cover and unplug the spindle connector.
- Using a 5mm allen wrench, take off the 8 screws on either side of the spindle.
- Replace the spindle with a new one and tighten the screws to 14.70 N.m

Recommended Parts/tools:

Spindle - 30875-09

Limit switch replacement

X-axis

- Use a 2mm allen wrench and take off the cover plate on the Y1 side of the gantry.
- Using a 2.5mm allen wrench take off the 3 screws that hold the X limit switch bracket in place
- Unplug the switch Molex connector
- Using a 3mm allen wrench remove the screw holding in the limit switch
- Replace with a new switch and add a zip tie to secure the cable

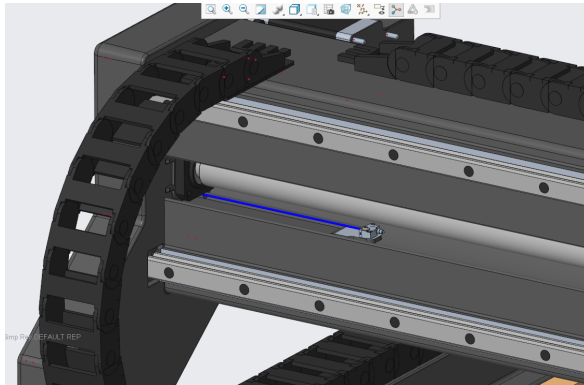

Y-axis

- Use a 2mm allen wrench and take off the cover plate on the front of the Y axis
- Using a 2.5mm allen wrench take off the 2 screws that hold the limit switch bracket
- Unplug the switch Molex connector
- Using a phillips head screwdriver and pliers remove the screw and locknut holding in the limit switch
- Replace with a new switch and add a zip tie to secure the cable

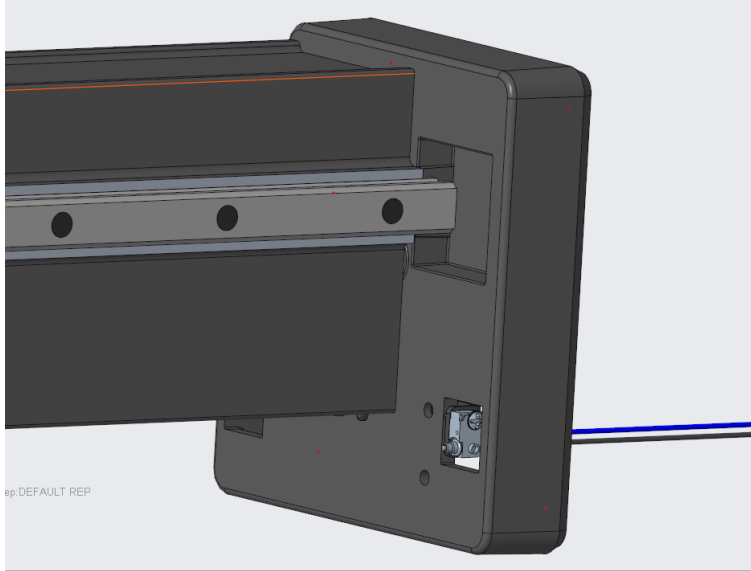

Z-axis

- Use a 2.5mm allen wrench and take off the plastic cover on top of the Z axis.
- Use a 3mm allen wrench and take off the 2 screws on the top and 2 screws at the back of the Z axis plate holding the Z axis cover in place
- Use a phillips head screwdriver to remove the screw holding in the limit switch
- Replace with a new one and add a zip tie to secure the cable

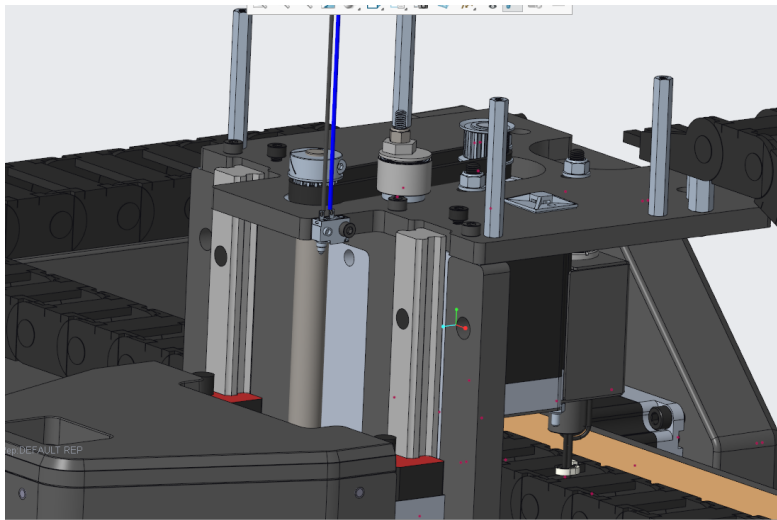

Recommended Parts/tools:

- Limit Switch - SKU 30875-01